

KINGPIN

ALARMED EMERGENCY ESCAPE BOLT

KEY FEATURES

- UK Patent No 2 182 712
- Tamper resistant
- Concealed fixings
- Resetting only by keyholder
- No glass or acrylic fragments
- High level of security from unauthorised entry
- Simple, single-action operation in an emergency
- Readily usable by the elderly and the handicapped
- Built-in 110dB alarm – added safety, security and a deterrent to casual use
- Options include:
 - Extended bolt shoots (see leaflet TK3)
 - Through-door kit for either-side operation (TK4)
 - Lock options – pass and master

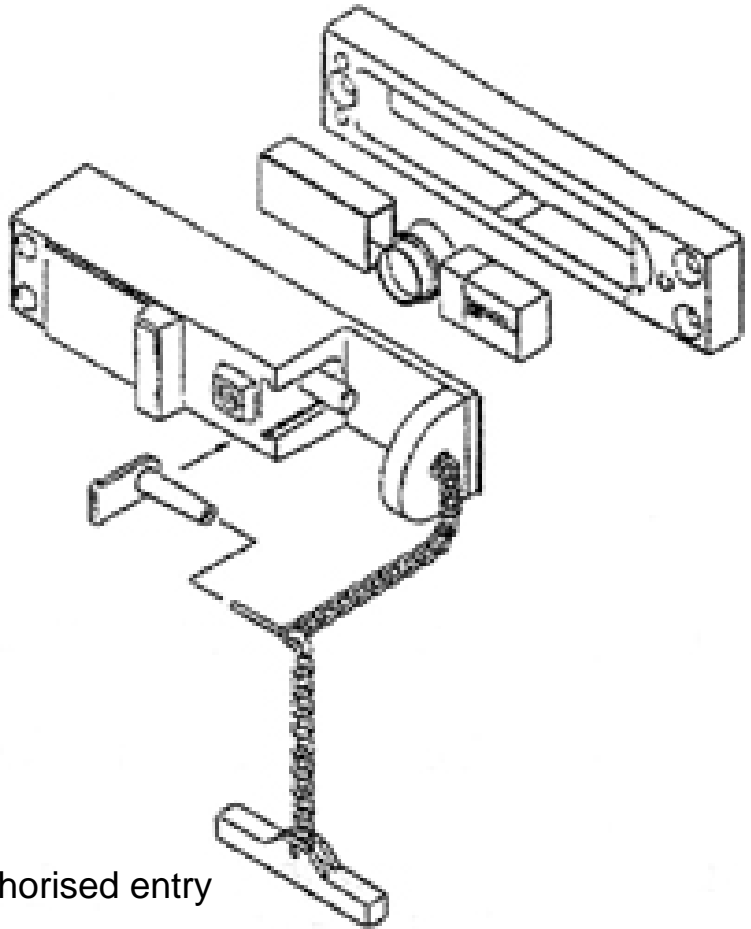

EMEXCO LIMITED

Unit 3, Dial Close, Seend,
Melksham, Wiltshire. SN12 6NP
United Kingdom
Tel. 00 44 (0) 1380 828900
Fax. 00 44 (0) 1380 828999

CE
1121-CPD
ETA 04/0051

KINGPIN

ALARMED EMERGENCY ESCAPE BOLT

Component List

– Kingpin Alarm Bolt	1
– Keep (Standard)	1
– Spare Plastic Component	1
– Fixing Screws	6
– Battery	1
– Sign	1
– Instruction Leaflet	1

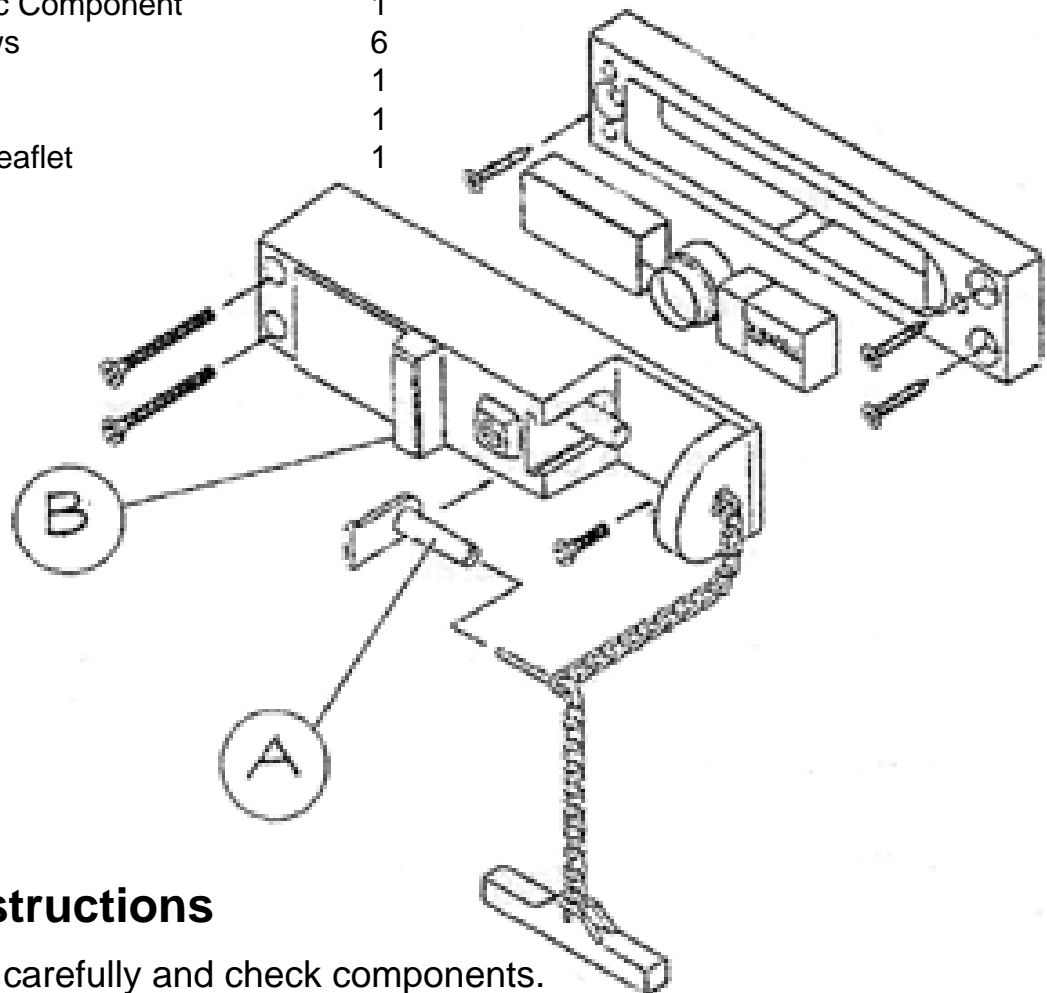

Fitting Instructions

1. Unpack carefully and check components.
2. Release installed plastic component (A) by easing tension on bolt spring using slider (B), unlock and slide plastic component free. Release slider gently.
3. Three fixing holes are now revealed. Separate bolt body from alarm base by undoing and removing the three screws. Select a suitable location on the door, a height of 1m above the floor is usually most convenient.

EMEXCO LIMITED

Unit 3, Dial Close, Seend,
Melksham, Wiltshire. SN12 6NP
United Kingdom
Tel. 00 44 (0) 1380 828900
Fax. 00 44 (0) 1380 828999

CE
1121-CPD
ETA 04/0051

KINGPIN

ALARMED EMERGENCY ESCAPE BOLT

4. Outward Opening Door

With the door closed, offer the alarm base to the door, leaving a 4-5mm gap between the door-stop and the bolt (the thickness of the standard keep supplied can be used as a temporary spacer). Mark the position of the fixing holes and drill pilot holes in the door.

Inward Opening Door

With the door closed, offer the alarm base to the door with the end of the bolt flush with the opening edge of the door. Mark the position of the fixing holes and drill pilot holes in the door.

5. Screw the Kingpin bolt to the door using the 3 off 12×2” screws provided. Ensure that the fixing screws engage with solid material and NOT just the skin of a hollow door. Connect up the battery and position in battery compartment and tuck wires away from trapping hazards.

6. Connect the body to base wiring plug and with the slider pushed towards the bolted position, re-position the KINGPIN bolt on the base, taking care to tuck the wiring away from the microswitch and any danger of trapping. Gently release the slider and re-attach the bolt to the base using the three screws provided.

Test the alarm by turning the key in the lock. If the alarm is found not to operate, gently adjust the microswitch tongue which may have been distributed in transit.

7. Keep – Outward Opening Door (Use Standard Keep)

With the door closed, mark the position of the keep on the door-stop by advancing the bolt shoot towards the ‘secured’ position. Drill a 16mm hole in the door-stop I the marked position, rebate for the depth of the keep and fix the keep with the 2 off 12×1” screws.

EMEXCO LIMITED

Unit 3, Dial Close, Seend,
Melksham, Wiltshire. SN12 6NP
United Kingdom
Tel. 00 44 (0) 1380 828900
Fax. 00 44 (0) 1380 828999

1121-CPD
ETA 04/0051

KINGPIN

ALARMED EMERGENCY ESCAPE BOLT

Keep – Inward Opening Door (Use Pull-Side Keep)

With the door closed, mark on the door frame the position for the keep. Rebate the door frame to take the keep. Trial align the keep with the door closed using the bolt shoot as a guide. Carefully avoiding moving the keep, screw the keep to the door frame using 3 off 12×1” screws.

8. With the door closed, check to ensure free movement and correct alignment of the bolt shoot in the keep.
9. Set bolt to secure door and fix self-adhesive sign to the door in close proximity to the bolt.

NB. Modern Printed Circuit Boards (PCBs) are robust and reliable. However, avoid touching the board and its components.

EMEXCO LIMITED

Unit 3, Dial Close, Seend,
Melksham, Wiltshire. SN12 6NP
United Kingdom
Tel. 00 44 (0) 1380 828900
Fax. 00 44 (0) 1380 828999

1121-CPD
ETA 04/0051